

Since the usage and finishing of the product is not under our control, we accept no liability for the success of our products as per the accompanying product data sheets and in accordance with our general terms and conditions of sale. The properties listed here represent no guarantee with respect to the eventual use of our products. We reserve the right to make changes due to technical advances. Any other technical information given in the course of a consultation must be confirmed in writing. Colours shown here are restricted by the printing techniques and may differ from those exhibited by the products themselves. We also reserve the right to make alterations to the product technology or design. Only the current version of this data sheet is valid. Such versions are accessible by anyone via the internet. The issue of the latest data sheet invalidates all those that have been published beforehand.

# DUROSOL

1/2

## Square Edge profiles – The perfect protection

- Information Sheet -



Aluminum / Brass

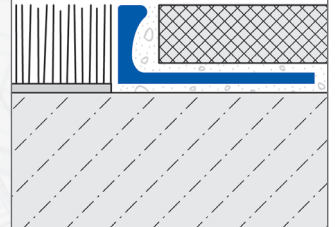

Stainless steel

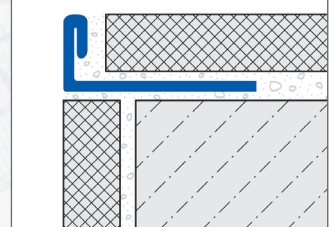

### APPLICATION::

DUROSOL square edge profiles by Dural were especially developed for protection of tile edges. They are suitable for all domestic and commercial areas. Because of their special angle and different materials, it is possible to provide edge protection even in areas of permanent and strong stresses. These special profiles were designed to transfer impact stresses uniformly into the tile covering and base material. This minimizes the chances of damage to the decorative covering.

Besides the protective function, the DUROSOL Square edge profiles also meet the highest deco-rative requirements. They provide clean transitions and limits, e.g. between carpet and parquet. They can be used as edge protection as well as for surface definition. A limited range of DUROSOL Square edge profiles is also available as flexible version - "Z-Flex".

### MATERIAL:

DUROSOL Square edge profiles are available in the following versions: brass natural, brass high gloss finish and chrome plated, aluminum natural, aluminum anodized and aluminum powder coated, stainless steel and stainless steel with high gloss finish.

### PROPERTIES:

Special profiles of **brass** are also applicable in industrial structures. They are resisting to high point loads and are mostly resistant against chemical substances occurring during tile fixing. Important: brass oxidizes when exposed to air, especially with high humidity. The surface is covered with a patina (protective layer) thus changing the appearance.

DUROSOL Square edge profiles made of **brass with a chrome finish** are extremely resistant to mechanical loading. They should not be allowed to come into contact with products that contain salt or hydrofluoric acid, however, since these will damage the surface. To ensure that the high gloss finish of the chrome layer is not impaired, residues of mortar and jointing compounds should be removed from the surface immediately.

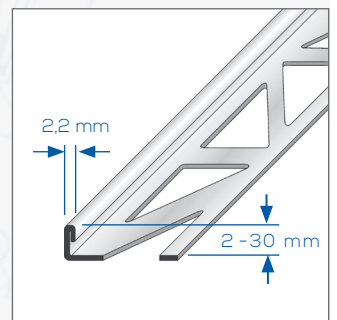
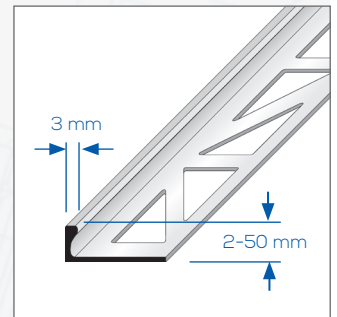

Dural

711 N Varnell Rd

Tunnel Hill, GA 30755

800.278.1956

[www.dural.com](http://www.dural.com)





## Square Edge profiles – The perfect protection

### - Information Sheet -

DUROSOL Square edge profiles in **aluminum** are used in applications where no exceptional chemical reaction is expected. Careful handling of cement materials is required to avoid corrosion. All residues of mortar, tile cement or joint cement are to be immediately removed from all visible surfaces because aluminum is sensitive to alkaline media's. The profile is to be completely embedded into the contact layer. This avoids cavities to generate where alkaline water might accumulate.

DUROSOL Square edge profiles of **anodized aluminum** are of special refinement and therefore the surface is usually not subject to changes. The visible surfaces however, have to be protected against any cement materials. Damages can occur because of scratching or abrasive objects.

DUROSOL Square edge profiles of **stainless steel** are especially suitable for areas subjected to high stresses due to chemicals and acids. They meet highest requirements of resistance to mechanical impact. Stainless steel profiles are used in foodstuff industry, swimming pools, in hospitals and breweries (V4A).

For all products and materials, the following applies: The suitability of the material with regard to the expected mechanical loading and chemical exposure must be investigated carefully in each individual case. The generally recognized rules of good engineering practice must always be observed!

### INSTALLATION:

1. Select DUROSOL Square edge profiles according to the tile thickness.
2. Apply tile cement in the appropriate area using a notched trowel.
3. Press DUROSOL Square edge profiles into the cement bed and align.
4. Completely level out the fastening legs.
5. Leaving a joint of 2-3 mm towards the profile, press the tiles tightly into the cement bed. Aligning the tiles so that they are flush with the upper profile edge.
6. Fill the space between tiles and profiles completely with joint grout.

### CARE AND MAINTENANCE:

DUROSOL angular closing profiles do not require any special care. Oxidation layers on brass and aluminum profiles can be removed with polishing compounds. A permanent removal however, is not possible. For profiles of special steel it is recommended to use chrome polishing solution. It will provide for a bright appearance. Special steel profiles exposed to very aggressive mediums should be cleaned from time to time with mild cleaning materials. The cleaning materials have to be free from hydrochloric acid and hydrofluoric acid and must not be abrasive.

### PRODUCT DATA:

<b>MATERIAL:</b>	- Aluminum natural, Aluminum anodized or Aluminum powder coated - Brass natural, Brass („Star“ with peel-off strip) or Brass chrome plated („Star“ without peel-off strip) - Stainless steel or Stainless steel high gloss („Star“ with peel-off strip) Mat. 304/1.4301 (V2A), Mat. 316/1.4404 (V4A)
<b>LENGTH:</b>	100 cm, 250 cm
<b>HEIGHT:</b>	Aluminum: 2-50 mm / Brass: 3-50 mm / Stainless steel: 2-30 mm
<b>VISIBLE SURFACE:</b>	Aluminum/Brass: 3 mm / Stainless steel: 2,2 mm

Dural

711 N Varnell Rd.

Tunnel Hill, GA 30755

800.278.1956

[www.dural.com](http://www.dural.com)